



REVISED 01/2025

2025 NEWS DIVISION RULES

Per New Jersey State law, It is now absolutely mandatory that all cars racing in the New Egypt Speedway Wingless Sprint division (NEWS) have a fire suppression system installed. The system shall have a minimum 5lb bottle securely attached to the frame of the vehicle. The bottle shall have an SFI label attached in plain view with an SFI spec of minimum 17.1 or 17.3 or greater and a date of no more than two years old. Every bottle must have a gauge attached and in plain view showing the bottle's state of charge. There must be either a mechanically activated trigger mechanism which is accessible and activated by the fully seated and strapped driver or an automatic trigger device which is activated automatically by heat. A minimum of one discharge nozzle is required. Directed onto the driver.

If your question is not in these rules, do not assume it is legal. Ask first!

This class "Northeast Wingless Sprint Cars" is intended to offer an affordable sprint car class utilizing a GM 602 crate motor along with a transmission and starter for convenience. To keep in the spirit of "affordability" we are asking that after your initial car purchase that you do NOT buy any more titanium parts for it that didn't come with the car. We realize it's difficult to buy a good used car that doesn't have titanium parts. At this time this doesn't seem to show any advantage out on the track since there is no wing and a crate motor. If at some time it's noticed that excessive use of titanium parts is believed to be creating an advantage, then changes will be made.

CHASSIS SPECIFICATIONS:

1. Any commercially produced chassis that is used in modern day sprint car racing i.e.- WOO, URC, TSRS, PA 410s, etc. is permitted.
2. Roof wings and/or nose wings are NOT permitted.
3. Halo bars above the drivers head are MANDATORY. All cars will be required to maintain the NJ State required 4 inches of clearance between the top of the seated and strapped driver's helmet and the TOP of the roll cage.
4. SFI certified high density roll bar padding at any point where the seated driver's head is within 2 inches of any roll bar is mandatory.



2025 NEW EGYPT SPEEDWAY NORTHEAST WINGLESS SPRINT RULES

5. Five point racing harness with arm restraints are mandatory. Per NJ State law, all harnesses must be SFI certified and be in service no more than two years from the date of manufacture.
6. Aluminum or carbon fiber racing seat securely bolted to the frame in no less than six locations is mandatory. Full containment seats are MANDATORY.
7. Steering wheel pad and sprint car style knee protection is mandatory.
8. All cars must have a mandatory master battery shut off switch which immediately kills all electrical functions of the race car mounted inside the cockpit, is well marked, and is easily accessible by the driver and any Speedway safety personnel.
9. All cars must have a well marked fuel shut off valve also inside the cockpit and easily accessible by the driver and any Speedway safety personnel.

CHASSIS SPECIFICATIONS:

1. Front suspension shall be conventional straight axle sprint car type with king pins and torsion bars or coil overs.
2. Rear suspension shall be conventional sprint car torsion rear suspension or coil overs.
3. Rear axle must be standard sprint car style rear or small 305 rear. No midget or hybrid style rear ends.
4. Any transmission is allowed, as long as it utilizes an internal clutch, which is operated by the drivers hand or foot and can be put into neutral.
5. All cars must be outfitted with an on board starting system and must be able to be electric started from the driver's seat. Battery must be completely sealed or spill proof gel type.
6. Drive shaft must be encased inside an aluminum or steel tube (torque tube).
7. ABSOLUTELY NO TITANIUM OR CARBON FIBER DRIVE LINE PARTS ARE PERMITTED.

8. Front sway bar is optional



2025 NEW EGYPT SPEEDWAY NORTHEAST WINGLESS SPRINT RULES

BRAKES:

1. All cars must have a good working sprint car style braking system consisting of one rear inboard caliper with four pistons and a steel or aluminum rotor OR two outboard calipers with two pistons and a steel or aluminum rotor only. NO TITANIUM OR CARBON FIBER BRAKE ROTORS ARE PERMITTED.
2. Single front brake is mandatory. Dual front brakes are optional.

SHOCKS:

1. Any steel or aluminum threaded body or steel body shock absorber WITHOUT Schrader Valves are permitted. Shocks can NOT have any adjustments which are accessible by the driver while sitting in the driver's seat.

WHEELS/TIRES:

1. Any brand of aluminum sprint car wheels only.
2. Any used sprint car tires are permitted. Any new tires purchased must be American Racer. The left rear may be any tire of the racer's choice.

GENERAL RULES:

1. Sprint car tail tank with bladder inside and approved vented filler cap is mandatory. Fuel tank must be protected from rear impact by a welded bumper assembly securely attached to the frame in at least four places.
2. Front single rail bumper is required.
3. Dual, nerf bars or "battle bars" are MANDATORY.
4. All cars must have an AMB TransX 260 transponder on the right side behind the front torsion bar tubes on the vertical bracket. The fitted transponder box shall be mounted as close as possible to the ground, but not protrude below the frame rail. It is the responsibility of the competitor to ensure that the transponder is in

quality working condition, fully charged and is securely mounted and is in a suitable position with brackets as outlined below.



- 2025 NEW EGYPT SPEEDWAY NORTHEAST WINGLESS SPRINT RULES**
- 5. Effective at the start of the 2021 Racing Season, all drivers are required to wear a full-face helmet meeting Snell specification SA2015 or newer.**



2025 NEW EGYPT SPEEDWAY NORTHEAST WINGLESS SPRINT RULES

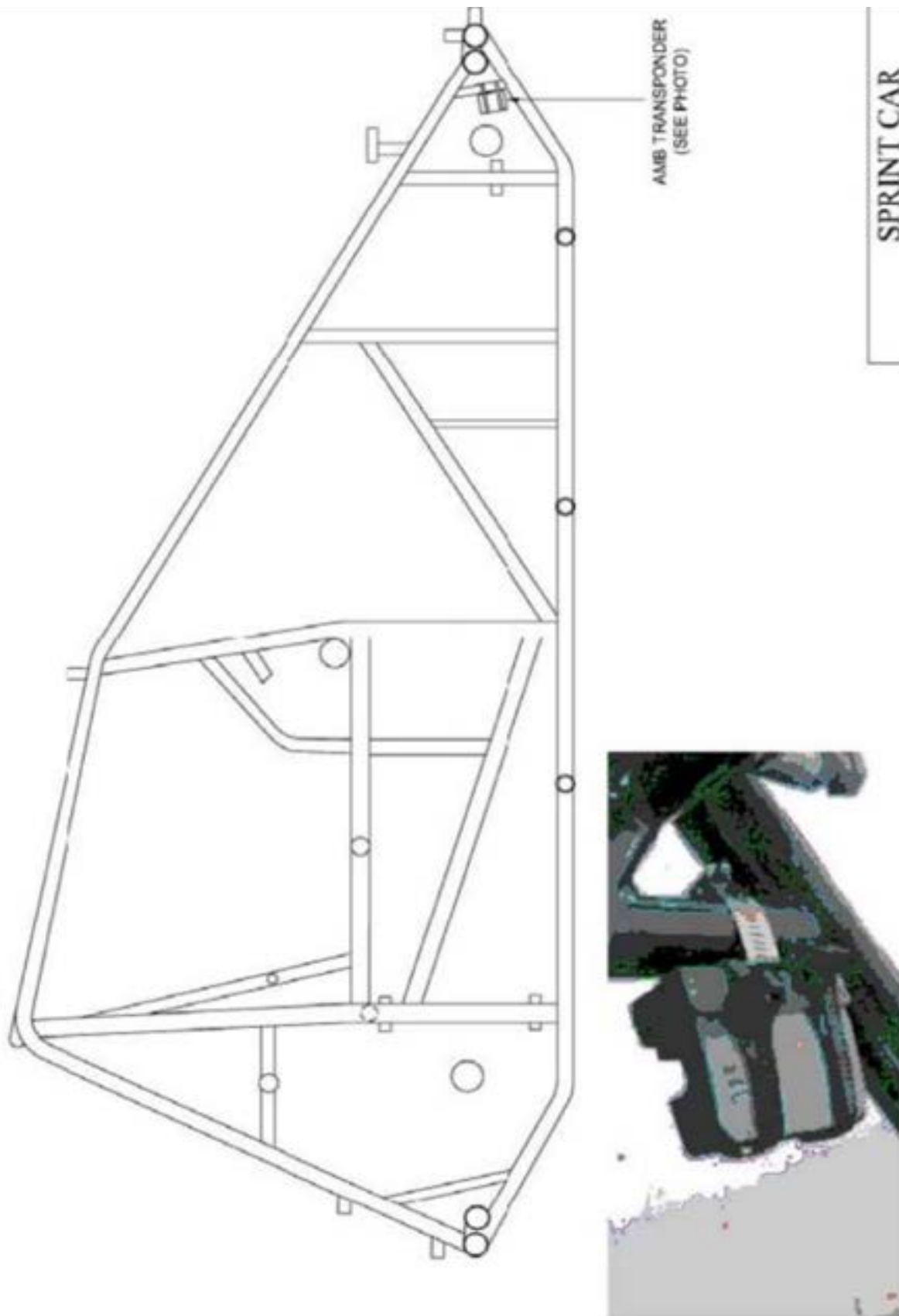



2025 NEW EGYPT SPEEDWAY NORTHEAST WINGLESS SPRINT RULES

ENGINE:

A sealed general motors 602 crate engine is the only engine permitted in the crate division. Any 602 crate engine which has ALL of the factory seals intact and a secondary set of seals affixed, NES preferably. All new engines must be purchased either through NES or RUSH only

ALL ENGINES MUST REMAIN AS DELIVERED BY GENERAL MOTORS INCLUDING HARMONIC BALANCER, DISTRIBUTOR, VALVE COVERS, SPRINGS, ROCKER ARMS, SEALS, ETC. IT IS STRICTLY FORBIDDEN TO TAMPER WITH THE FACTORY AND/OR OTHER SEALS IN ORDER TO GAIN ACCESS TO THE INTERNAL WORKINGS OF THE ENGINE. ANYONE CAUGHT TAMPERING WITH THE FACTORY AND/OR OTHER SEALS SHALL IMMEDIATELY HAVE THEIR ENGINE CONFISCATED BY NES, FINED \$500.00, AND HAVE THEIR NES LICENSE SUSPENDED FOR NOT LESS THAN ONE YEAR, AND BE STRIPPED OF ALL POINTS ACCUMULATED UP UNTIL THE TIME OF THE INFRACTION. IN THE EVENT THAT AN ENGINE SUSTAINS INTERNAL DAMAGE OR WEAR THAT REQUIRES THE REMOVAL OF ONE OR MORE SEALS, THE ENGINE MAY BE TAKEN TO A CERTIFIED RUSH FACILITY WHERE IT MAY BE REPAIRED, OR REBUILT AND THEN RESEALED WITH RUSH SEALS ONLY. RUSH ARE THE ONLY ACCEPTABLE SEALS THAT MAY REPLACE A GM FACTORY SEAL AND NO OTHER SEALS WILL BE ACCEPTED OR PERMITTED. ALL OTHER NES CRATE RULES, CARBURETOR, FUEL, ETC WILL STILL APPLY. ANY ENGINE, MAY BE SUBJECT TO FURTHER INSPECTION AT ANY TIME EITHER INITIATED BY NES TECH INSPECTORS, OR BY ANOTHER COMPETITOR PROTEST.



2025 NEW EGYPT SPEEDWAY NORTHEAST WINGLESS SPRINT RULES

IGNITION:

1. No ignition amplifier boxes of any kind are permitted. MSD heavy-duty distributor cap, rotor, module, and coil mounted in stock location are permitted.
2. All cars are required to use an unaltered MSD/DIRT rev limiter box part #8727CT set at 6400 RPM's. Box must be mounted on engine side of firewall. These will be checked periodically at random by tech.
3. **NO FORM OF ELECTRONIC OR MECHANICAL TRACTION CONTROL IS PERMITTED. ANYONE CAUGHT USING TRACTION CONTROL WILL BE STRIPPED OF ALL POINTS, FINED NO LESS THAN \$500, AND HAVE HIS/HER NEW EGYPT SPEEDWAY LICENSE SUSPENDED FOR NOT LESS THAN ONE YEAR.**

FUEL/FUEL SYSTEM:

1. ANY fuel system located in the front of the engine or Driver's compartment is allowed.
2. Any Holley 650, 650HP, 650 Ultra HP, 750, 750HP, or 750 Ultra HP or a reasonable aftermarket copy there of is permitted. All carburetors must be of the traditional double- pumper design with mechanically operated secondaries. No vacuum secondaries are permitted. No external modifications are allowed, including modifications visible looking into the venturies and the throttle bores. Carburetors must maintain stock venturie throttle bore, and booster dimensions. Conventional Holley fuel feed locations only. No cutting and or polishing, and must remain stock appearing in all respects. Choke horn may be removed. These are the only carburetors permitted. Carburetors will be checked both visually and by the use of go-no-go gauges to check for illegal modifications. Any carburetor may as a courtesy be checked for legality by NES tech officials at any time. Contact tech officials for information. Billet metering blocks and baseplates are permitted. Main bodies and fuel bowels must remain cast. All carburetors must pass gauges to be legal.



2025 NEW EGYPT SPEEDWAY NORTHEAST WINGLESS SPRINT RULES

3. Maximum one inch spacer plate is permitted. Additional ¼" plate for throttle linkage okay.
4. Conventional style round air cleaner only.
5. New Egypt Speedway sells VP Racing fuel only. **Effective immediately. It is absolutely mandatory that all fuel in the NEWS division be purchased from New Egypt Speedway. With the exception of open shows, and special events, it is forbidden to bring any other fuel or containers of fuel onto New Egypt Speedway property. All drivers or car owners in the above listed divisions will be required to purchase a minimum of five gallons of fuel on every race event. Fuel receipts will be verified and the date on the fuel receipt, MUST match the date of the racing event. At the end of every feature event, the list of registered cars will be compared vs the list of teams who purchased fuel. This does not mean that fuel samples need not be taken. Normal tech procedures will still apply. Anyone who has not purchased a minimum of five gallons of fuel WILL NOT BE PAID ! In the event that a feature event can not be run due to unforeseen circumstances, ie, weather, etc, Fuel purchases will be honored the following week.**

There is only one (1) fuel available for use in the NEWS division.

- Alcohol (methanol)

Fuels will be subject to three (3) tests.

- (1) Visual inspection
- (2) Odor test
- (3) a water test and specific gravity test.

In the event that any fuel fails any of the above mentioned tests, the fuel is deemed illegal and the car and driver will be disqualified from that race event. Fuel may be sent to an outside, independent laboratory for further analysis if deemed necessary by NES tech officials.



2025 NEW EGYPT SPEEDWAY NORTHEAST WINGLESS SPRINT RULES

It is forbidden to mix any fuels together.

Top lube will be permitted and will be sold by NES only and is to be used at the rate specified by NES tech officials.

Any other fuel additives of any type will be strictly prohibited.

If a racer competes at a neighboring facility, it is entirely his or her responsibility to make sure that his or her fuel system is cleaned of any residual fuel. The standard that will be used for fuel analysis will be the fuel that is taken from NES bulk tanks on that particular race day and NES will not be held responsible for a “dirty” fuel test.

COOLING SYSTEM:

1. Any conventional belt driven aluminum or cast-iron water pump is permitted.
2. **NO** crank driven direct front drive water pumps.

EXHAUST SYSTEM:

1. **Schoenfeld headers part #1052LV are the only permitted headers. Headers must remain as produced by the manufacturer with no modifications or alterations, Restrictors are not permitted.**

WEIGHT:

1. This car must weigh a minimum of 1575 lbs. with the driver at the completion of all qualifying races and the feature event.